

INSTALLATION INSTRUCTIONS FOR MODEL H00984

IMPORTANT: REVIEW ALL INSTRUCTIONS, PARTS LISTS, & INSTALLATION DIAGRAMS BEFORE
STARTING INSTALLATION

HORN ASSEMBLY

1. Follow steps 1-5 for both horns. For best results, mount horns in an unobstructed opening for sound to carry straight ahead. If possible mount with a slight downward angle to allow moisture to drain out.
2. For roof mount installation: If vehicle is equipped with interior roof trim panel, remove to install horn. Drill 1/2 in. and (2) 5/16 in. holes (use mounting pad for template, item# 3) in position desired for horn. Place mounting pad between base of horn and top of vehicle roof. Place tension washer (item# 4) on mounting elbow (item# 7) as shown in figure 1, next thread the elbow into the base of the horn from under the roof. Insert (2) screws (item# 1) through hole of horn base and roof, attach lock washer (item# 5) and hex nut (item# 6). Connect nylon tubing (item# 10) to mounting elbow using brass insert (item# 8) and tube nut (item# 9). Then run tube to tank location and replace trim panel.

TANK ASSEMBLY

1. Select mounting location for air tank (item# 28) keeping in mind the orientation of the tank and visibility of the air gage. (See Figure 1 for sample installation)
2. Thread brass fitting (item# 16) into brass cross (item# 20), then install brass fitting into either tank outlet. Next thread other brass fitting (item# 16) into brass cross and into solenoid threaded inlet (item# 15). In remaining (2) outlets of the brass cross, thread tire valve (item# 22), shut off (item# 21) and brass fitting (item# 25).
3. Thread brass tee fitting (item# 19) into remaining tank outlet. Thread the pressure gage (item# 18) and pressure switch (item# 17) into the tee.

CAUTION: Tighten pressure switch and pressure gage on brass hex body only.

4. To mount tank drill (2) 11/32 in. diameter holes spaced 4 in. apart in a rigid surface. Insert tank studs through the holes and secure with locknuts (item# 29).

COMPRESSOR ASSEMBLY

1. As shown in figure 2, slide the (2) grommets (item# 33) into slots. Next push the (2) brass eyelets (item# 32) into the grommets. Pull the (4) bumpers (item# 35) through the (4) round holes on the bracket.
2. Clamp compressor head and install brass fitting (item# 25) into air outlet as shown in figure 1.
3. Mount compressor on rigid support. Do not mount on fender well, firewall or other flexible material. Locate compressor in area with good air flow and away from road surface to avoid excessive water and dirt conditions.
4. Mounting requires (2) holes spaced 23/16 in. apart, each having a diameter of 7/32 in.
5. To mount compressor, insert 10-32 bolt (item# 31) through the brass eyelet and through the 7/32 in. hole. Secure with the 10-32 nut (item# 34) as shown in figure 2. **Do not over tighten mounting bolts.**
6. Connect nylon tubing from air outlet fitting to the brass male connector on the tank as shown in figure 1.

ELECTRICAL ASSEMBLY

1. As shown in figure 1 connect orange (+) wire from compressor motor to either pressure switch terminal. Next, connect fuse holder (item# 26) to the other pressure switch terminal. Install other end of fuse holder to "ignition activated" accessory terminal in fuse panel. Attach motor's black wire (-) to metal ground.
2. As shown in figure 3 mount toggle switch (item# 36) on or under the dash in a location easily accessible to the driver. Connect wire (item# 37) from vehicle ground to either solenoid terminal (item# 15). Connect other solenoid terminal to either terminal on the toggle switch. Connect remaining toggle switch terminal in line with the existing horn wire using a wire splice connector (item# 38). With toggle switch in "off" position, only the vehicles electric horn will operate. With switch in "on" position, air horns and electric horn will be operated.

NOTE: Compressor starts automatically when pressure drops below 110 psi. If more than 4 1/2 minutes are required to pump tank to full pressure (110-135 psi) with engine running and compressor does not shut off, check all connections with soapy water or bubble solution for leaks. Use thread sealant on all uncoated pipe threads. Maximum cycle time 7 minutes with 30 minute cool down.

CAUTION: Check local noise abatement ordinances to avoid legal violations.

INSTALLATION INSTRUCTIONS FOR MODEL H00984

INSTALLATION DIAGRAM

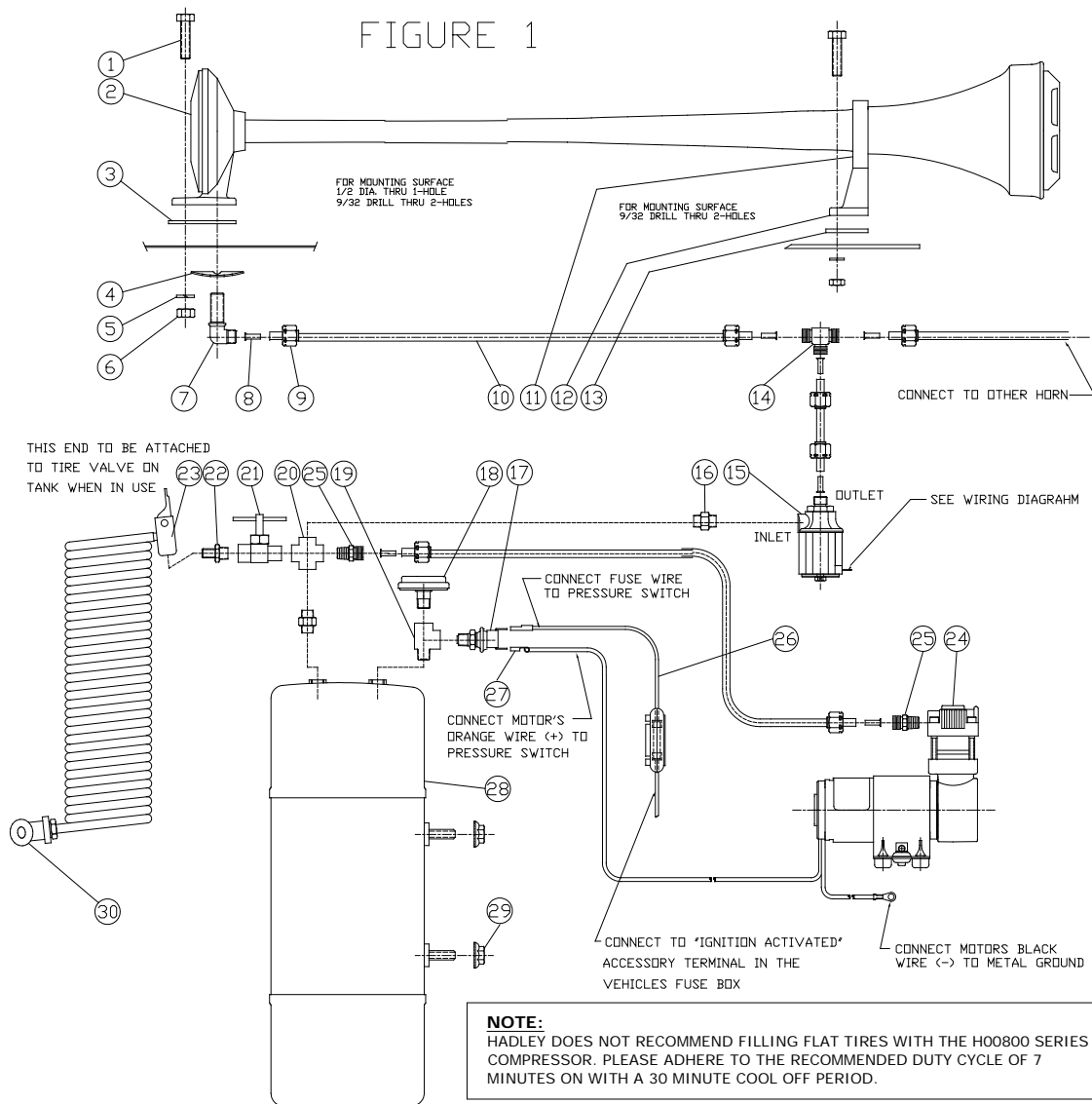
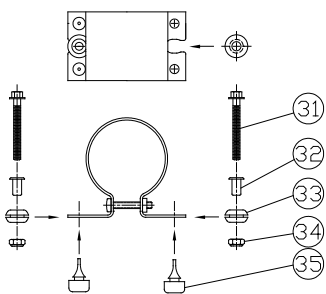
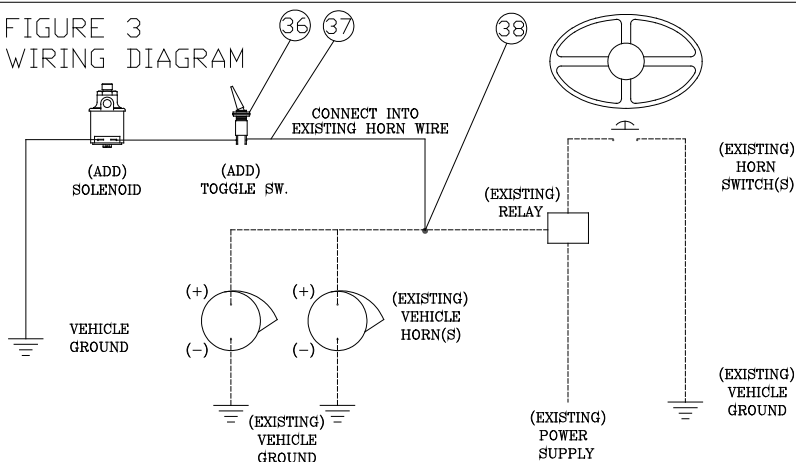

FIGURE 2
BRACKET ASSEMBLY













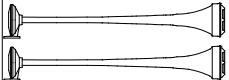
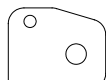
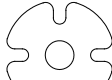

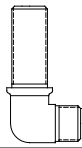

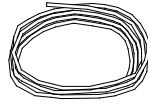
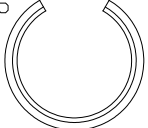
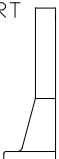
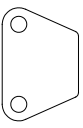
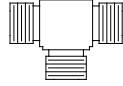
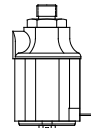

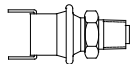
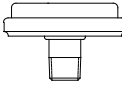
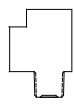

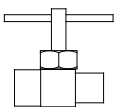

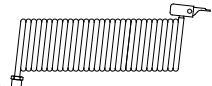

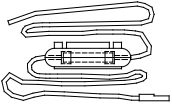

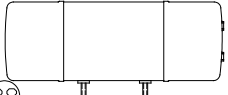
ECR 4496 REV E
FILENAME: H14024.DWG

FIGURE 3
WIRING DIAGRAM



INSTALLATION INSTRUCTIONS FOR MODEL H00984

PARTS LIST

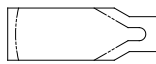
| | | | | |
|---|--|--|--|---|
| <p>(8)-QUANTITY MOUNTING BOLT H12801</p>  <p>①</p> | <p>(2)-QUANTITY HORN ASSEMBLY H00984-0</p>  <p>②</p> | <p>(2)-QUANTITY BODY PAD H13727</p>  <p>③</p> | <p>(2)-QUANTITY TENSION WASHER H11553</p>  <p>④</p> | <p>(8)-QUANTITY LOCK WASHER H11306</p>  <p>⑤</p> |
| <p>(8)-QUANTITY HEX NUT H11305</p>  <p>⑥</p> | <p>(2)-QUANTITY MOUNTING ELBOW H11477</p>  <p>⑦</p> | <p>(8)-QUANTITY BRASS INSERT H12462</p>  <p>⑧</p> | <p>(8)-QUANTITY TUBE NUT H15522</p>  <p>⑨</p> | <p>(1)-QUANTITY NYLON TUBING 1/4" H1311020S</p>  <p>⑩</p> |
| <p>(2)-QUANTITY GROMMET H13725</p>  <p>⑪</p> | <p>(2)-QUANTITY TUBE SUPPORT H13723-1</p>  <p>⑫</p> | <p>(2)-QUANTITY BODY PAD H13724</p>  <p>⑬</p> | <p>(1)-QUANTITY UNION TEE H12644</p>  <p>⑭</p> | <p>(1)-QUANTITY SOLENOID KIT (12V) H00550B</p>  <p>⑮</p> |
| <p>(2)-QUANTITY BRASS FITTING 1/8 X 1/8 H11468</p>  <p>⑯</p> | <p>(1)-QUANTITY PRESSURE SWITCH H13940A</p>  <p>⑰</p> | <p>(1)-QUANTITY PRESSURE GAUGE 0-160 psi H14212</p>  <p>⑱</p> | <p>(1)-QUANTITY BRASS TEE 1/8 H14654</p>  <p>⑲</p> | <p>(1)-QUANTITY BRASS CROSS 1/8 H11830</p>  <p>⑳</p> |
| <p>(1)-QUANTITY SHUT OFF H14097</p>  <p>㉑</p> | <p>(1)-QUANTITY TIRE VALVE H12489</p>  <p>㉒</p> | <p>(1)-QUANTITY HOSE H00891-0</p>  <p>㉓</p> | <p>(1)-QUANTITY MODEL 850 COMPRESSOR</p>  <p>㉔</p> | <p>(2)-QUANTITY BRASS FITTING 1/4 X 1/8 H12553</p>  <p>㉕</p> |
| <p>(1)-QUANTITY FUSE HOLDER H15235</p>  <p>㉖</p> | <p>(5)-QUANTITY FEMALE TERMINAL H14620</p>  <p>㉗</p> | <p>(1)-QUANTITY AIR TANK H00751N</p>  <p>㉘</p> | <p>(2)-QUANTITY LOCK NUT 5/16 H12737</p>  <p>㉙</p> | <p>(1)-QUANTITY BALL CHUCK H14200</p>  <p>㉚</p> |
| <p>(2)-QUANTITY BOLT 10-32 H14168</p>  <p>㉛</p> | <p>(2)-QUANTITY EYELET H15224</p>  <p>㉜</p> | <p>(2)-QUANTITY GROMMET H15234</p>  <p>㉝</p> | <p>(2)-QUANTITY NUT 10-32 H14591</p>  <p>㉞</p> | <p>(4)-QUANTITY BUMPER H14572</p>  <p>㉟</p> |
| <p>(1)-QUANTITY TOGGLE SWITCH H12949</p>  <p>㊱</p> | <p>(1)-QUANTITY WIRE 16 GA. H12669-2</p>  <p>㊲</p> | <p>(2)-QUANTITY WIRE SPLICE CONNECTOR H13116</p>  <p>㊳</p> | <p>(1)-QUANTITY TEFLON THREAD SEALANT H13943</p>  <p>㊴</p> | |

ECR 4496 REV E
FILENAME: H14024.DWG

INSTALLATION INSTRUCTIONS FOR MODEL H00984

SOLENOID CLEANING PROCEDURE

1. Drain all air from tank.
2. Using 1/2" wrench, disconnect horn air line from solenoid.
3. Using 2/4" wrench, loosen and remove brass outlet fitting that the air line was attached to. Removal of this fitting allows access to inside chamber of solenoid valve.
4. Slowly remove plunger and spring from inside of valve to permit cleaning.
5. Inspect metal surface of plunger for corrosion build-up and remove with steel wool, emery board, or similar product. After thoroughly cleaning plunger surface, inspect rubber tip. Tip should be relatively smooth to allow proper seating against the brass outlet fitting.
6. After cleaning and inspecting the plunger, reassemble the solenoid. Place the spring back into the hole in the plunger and re-insert plunger (Spring end first) into the solenoid. To check for proper placement, simply depress plunger with fingertip. Plunger should travel in and out smoothly.
7. Place brass outlet fitting back into position and tighten with 3/4" wrench.
8. Re-attach air line to the outlet of the solenoid and tighten tube nut.
9. Procedure is now complete. Allow air tank to re-fill and your system will be back in full operation.
10. This procedure may have to be performed several times per year depending on horn use, climate, and/or horn mounting location.
11. If plunger and spring are no longer useable, a replacement kit is available. Hadley part number is HPB550-0

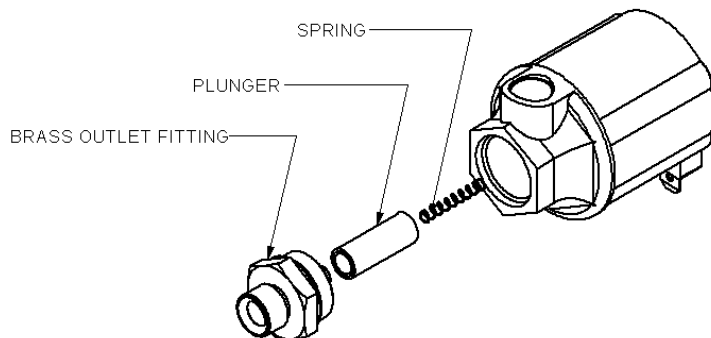

All Hadley products carry a limited warranty for 12 months from date of purchase. We will repair or replace, at our option, defects in material and workmanship during that period when product and proof of purchase are returned to our service department at the address below.



Hadley Products
Attn: Service Department
2851 Prairie SW, Suite D
Grandville, MI 49418

Service Department: (616) 249-8462
Main: (616) 530-1717 Fax: (616) 530-3283
www.hadley-products.com

MOUNTING TEMPLATES

