

H00500 SERIES HEIGHT CONTROL VALVE INSTRUCTIONS

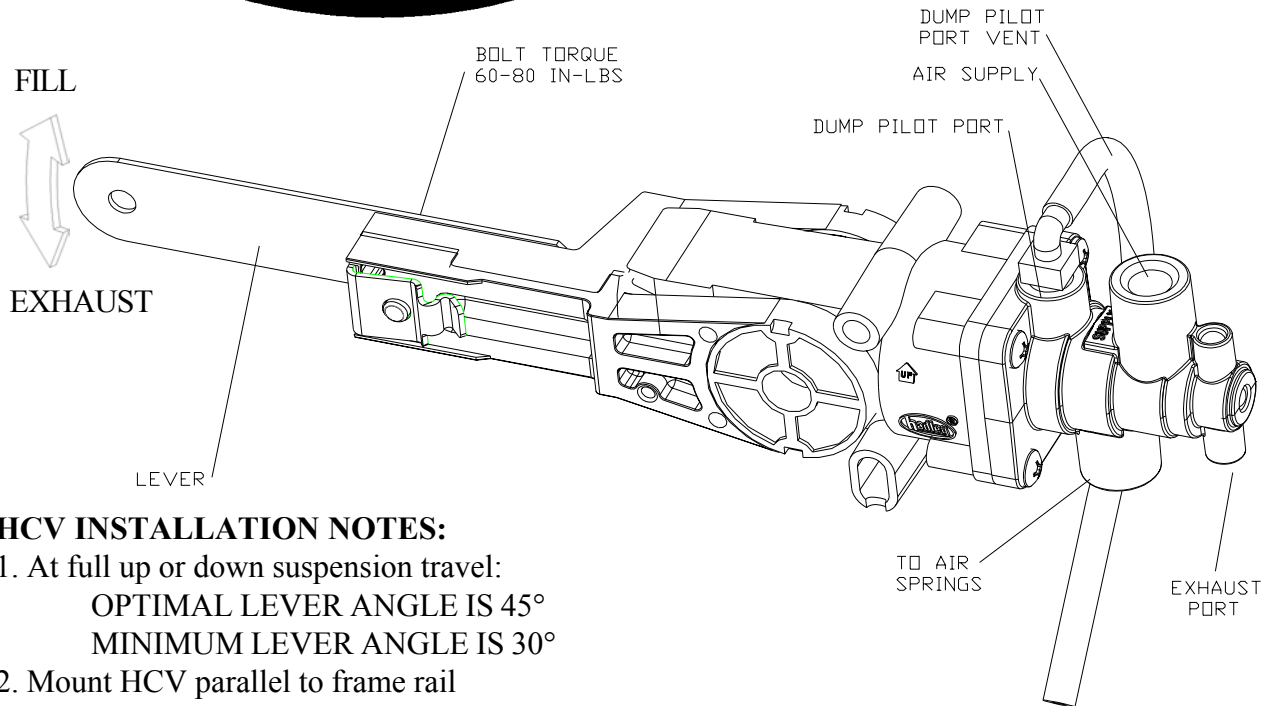

HCV INSTALLATION NOTES:

1. At full up or down suspension travel:
OPTIMAL LEVER ANGLE IS 45°
MINIMUM LEVER ANGLE IS 30°
2. Mount HCV parallel to frame rail
3. If **NOT** using the integral dump option, dump pilot port vent must be left in place.
4. If using integral dump option, remove dump pilot port vent and connect directly to 3-way selector valve.
Ensure that selector system is vented to atmosphere at all times (even when not being activated).

Note: Dump pilot port/system must not be plugged at any time as this may affect valve centering.

HCV INSTALLATION INSTRUCTIONS

Caution: Air lines are pressurized and may blow debris, USE EYE PROTECTION.

1. Disconnect and remove old valve.
2. Attach the Hadley H00500 HCV to the same mounting bracket. Or use the enclosed brackets as needed to mount the valve.
3. **Attach the proper length lever** to achieve 30° minimum fill and exhaust angle (see above notes). Check for any interference or straight lining of the valve lever and linkage through the entire suspension travel.
4. Reconnect the air lines to the H00500 HCV per the picture above. Connect the dump pilot port to a normally closed control valve.
5. Adjust the ride height of the suspension utilizing the H00500 HCV lever and the vehicle manufacturer's ride height recommendations. Install centering dowel to insure the valve dead band is at ride height.
6. Tighten all nuts 60 to 80 in-lbs.
7. Remove centering dowel.

PROBLEM	POSSIBLE CAUSE
Air springs flat	Obstructed air line Insufficient air pressure to suspension Defective Pressure Protection Valve Defective HCV (see test procedure) Air leak in system
Air springs raise to full height but do not exhaust	Obstructed air line Defective HCV (see test procedure)
Air springs deflate when parked	Leak in air system (check with soapy water) Defective HCV (see test procedure)
Suspension will not maintain proper height	Check dump port for proper venting (see installation notes 3 & 4) Obstructed air line Defective HCV (see test procedure)
Hard ride	Ride height out of adjustment (readjust per vehicle service manual)
Ride height unequal side to side for (2) valve system	Check dump port for proper venting (see installation notes 3 & 4) Reset ride height on each side (per installation instruction 5)

HCV TEST PROCEDURE

1. With a minimum of 90 psi at the supply port, rotate the lever up (as indicated on the side of the valve) 30° to 45° . Air should begin to flow into the air springs within seconds.
2. Rotate the lever to the neutral position. Air flow should stop.
3. Rotate the lever down 30° to 45° . Air should begin to exhaust from the air springs within seconds.
4. Rotate the lever to the neutral position. Air flow should stop.
5. If valve fails to flow air or shut off as specified, replace with a new one.

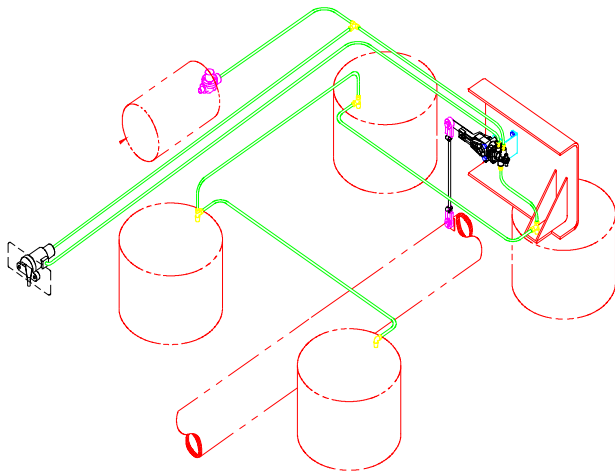

TYPICAL INSTALLATION

ELECTRIC SOLENOID AND REVERSE DUMP OPTIONS AVAILABLE

REASONS TO REPLACE THE HCV

- HCV did not pass the test procedure
- Air leaks from the HCV
- HCV is damaged

HADLEY PRODUCTS
2851 Prairie St SW
Grandville MI 49418
Telephone (616) 530-1717
Fax (616) 530-3283

Call or write regarding other
Hadley products: Cab or Chassis HCV's,
Air Horns, Mini Compressors, etc.