

General Installation Instructions

CHROME-PLATED AIR COMPRESSOR
H00850CA (INDIVIDUALLY PACKED)
H00850CB (BULK PACKED)

IMPORTANT: REVIEW ALL INSTRUCTIONS, PARTS LISTS, & INSTALLATION DIAGRAMS BEFORE STARTING INSTALLATION

1. As shown in the bracket assembly diagram, slide the (2) grommets into slots. Next push the (2) brass eyelets into the grommets. Pull the (4) bumpers through the four round holes on the bracket.
2. Note: Mount compressor on rigid support. Do not mount on fender well, firewall or other flexible material. Locate compressor in an area with good air flow and away from excessive water and dirt conditions. Mounting requires two holes spaced $2 \frac{3}{16}$ in. apart, each having a diameter of $\frac{7}{32}$ in. as shown in the bracket assembly diagram.
3. To mount compressor, insert the 10-32 screw through the washer, brass eyelet, and the $\frac{7}{32}$ hole. Secure with the 10-32 locknut and washer as shown in the diagram. **Do not overtighten mounting screws.**
4. Connect orange (+) wire of motor to a fused 20 amp circuit. Attach motor's black wire (-) to metal ground.

All Hadley products carry a limited warranty for 12 months from date of purchase. We will repair or replace, at our option, defects in material and workmanship during that period when product and proof of purchase are returned to our service department at the address below.



www.hadley-products.com

Hadley Products

Attn: Service Department
2851 Prairie S.W. Suite D
Grandville, MI 49418



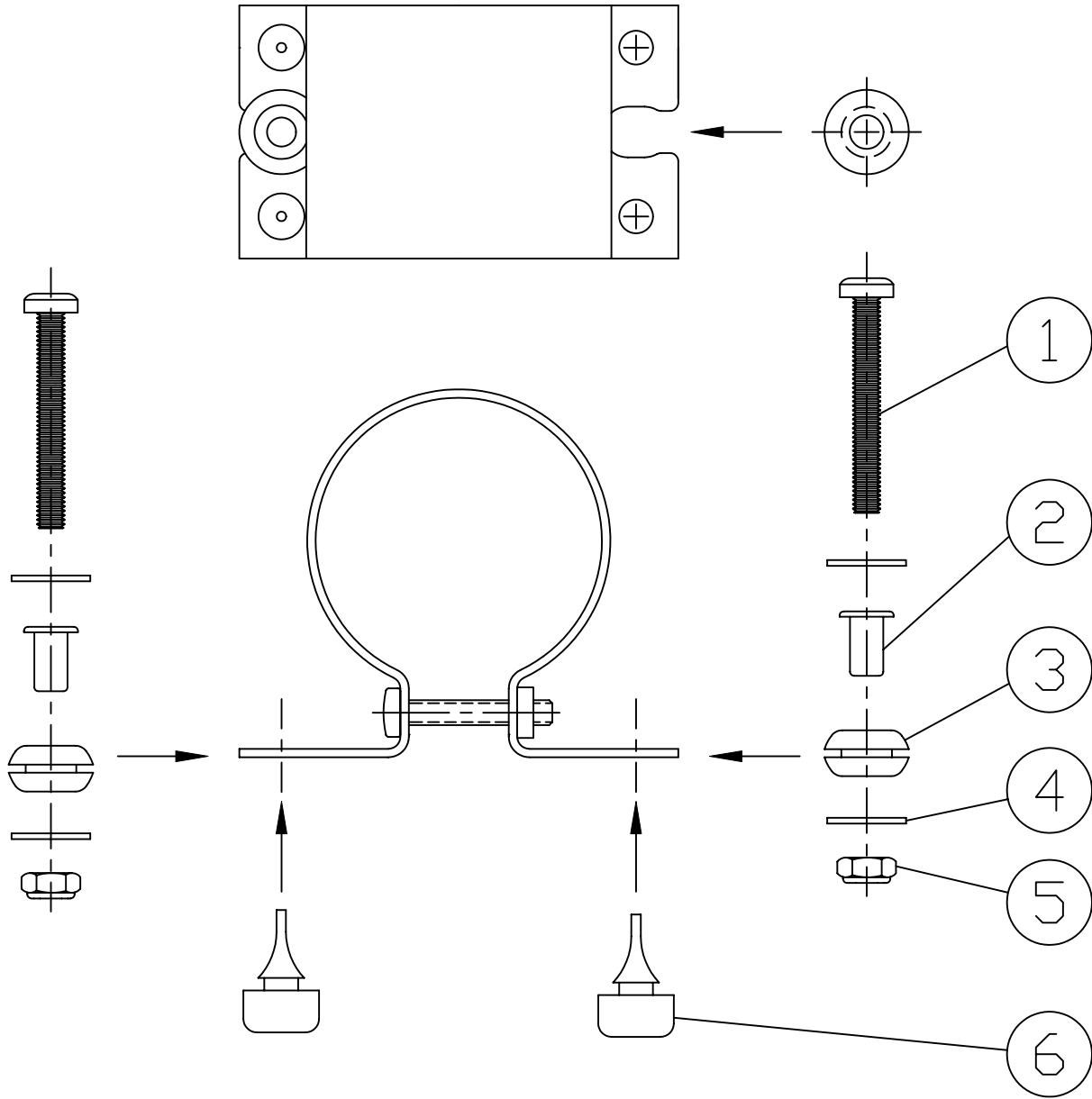

Service Department: (616) 249-8462
Main: (616) 530-1717
Fax: (616) 530-3283

BRACKET ASSEMBLY DIAGRAM

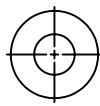

$\phi 7/32$ ——— $2 \frac{3}{16}$ COMPRESSOR MOUNTING TEMPLATE ——— $\phi 7/32$

PARTS LIST

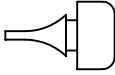
<p>(2)-QUANTITY SCREW H15289</p> <p>①</p> 	<p>(2)-QUANTITY EYELET H15224</p> <p>②</p> 	<p>(2)-QUANTITY GROMMET H15234</p> <p>③</p> 	<p>(4)-QUANTITY WASHER H15291</p> <p>④</p> 	<p>(2)-QUANTITY LOCKNUT H15290</p> <p>⑤</p> 	<p>(4)-QUANTITY BUMPER H14572</p> <p>⑥</p> 
--	--	---	--	---	--